

IF IN DOUBT - ASK!

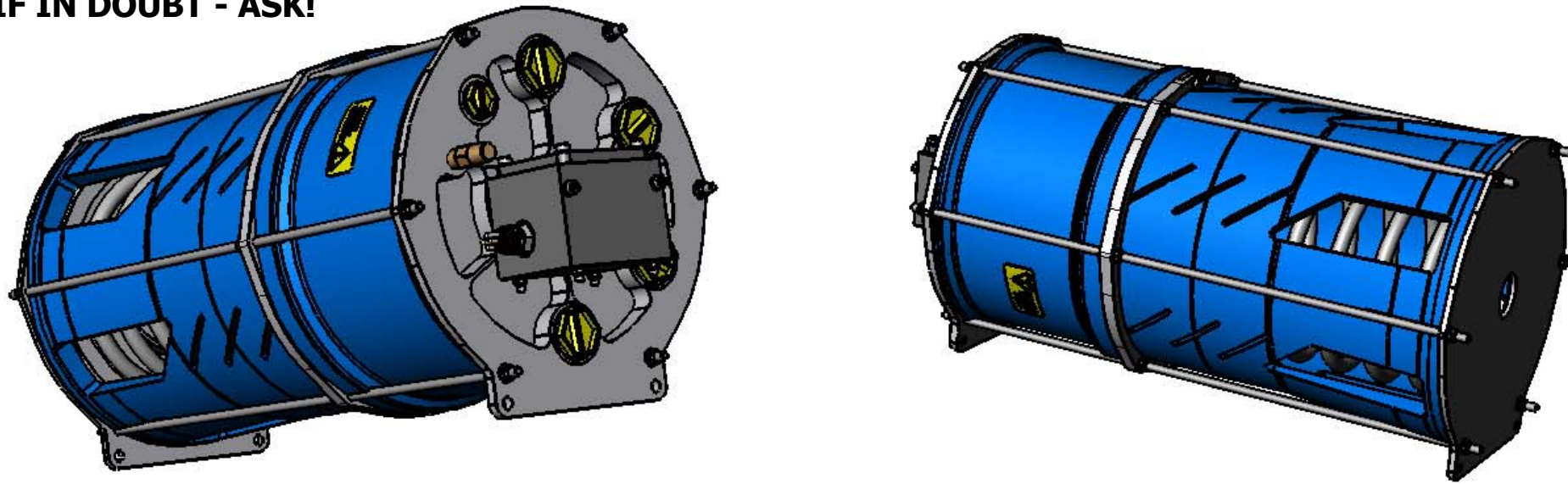

SPECIFICATION

| | Y Δ 5 | N Δ 5 |
|----------------------------|--------------|--------------|
| LEVEL SENSOR? (Y/N) | | |
| MASS IN AIR EMPTY: | 17.5 KG | 16.8 KG |
| MASS IN AIR FULL OF OIL: | 29.0 KG | 28.3 KG |
| MASS IN WATER EMPTY | 9.9 KG | 9.7 KG |
| MASS IN WATER FULL OF OIL: | 7.9 KG | 7.6 KG |
| PRESSURE WHEN FULL: | 0.48 BAR | 0.48 BAR |
| PRESSURE WHEN EMPTY: | 0.24 BAR | 0.24 BAR |

REMOVE SHARP EDGES

PART No:
SA-HC-13500-LS-XX-X
REFER TO PRODUCT FAMILY FOR VARIOUS OPTIONS ON PORTS AND LEVEL SENSORS

NOTES:
1. NUT TORQUE REQUIREMENTS ARE TO BE OBTAINED FROM THE BUILD & TEST PROCEDURE IN THE OPERATIONS & MAINTENANCE MANUAL

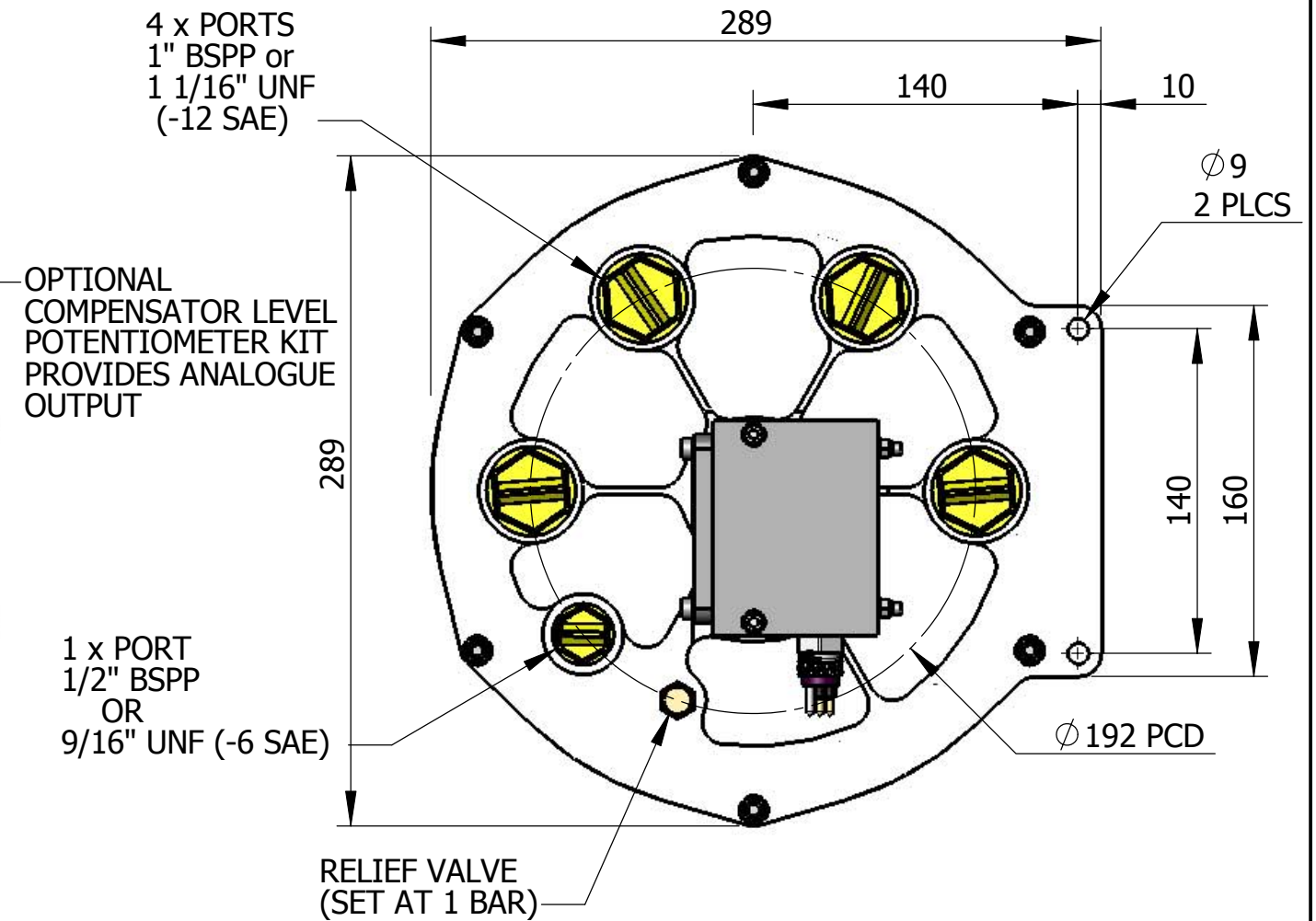
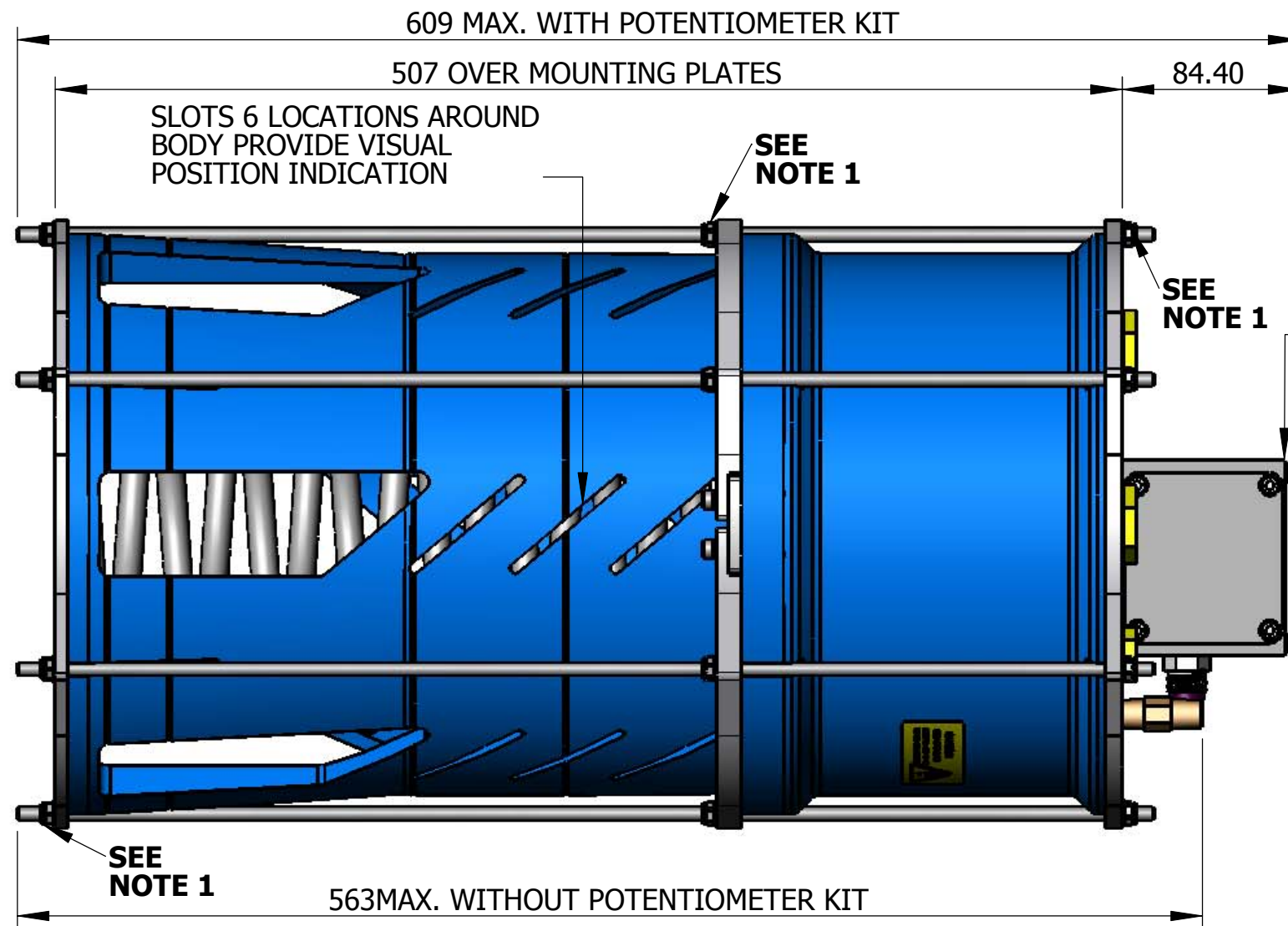

| REV | BY | DATE | DESCRIPTION | APP |
|-----|-----|------------|--|-----|
| 5 | AOL | 18/03/2009 | UPDATED MASS PROPERTIES & ADDED COLUMN FOR LEVEL SENSOR OPTION | |
| 4 | AOL | 18/02/2009 | MODIFIED PART NUMBER, UPDATED DIMENSIONS | |
| 3 | CMI | 06/11/07 | WEIGHTS MODIFIED | |
| 2 | ACR | 29/11/05 | MODEL TABLE ADDED | |
| 1 | CMI | 29/07/04 | APPROVED FOR MANUFACTURE | |
| A | CMI | 12/05/04 | PRELIMINARY FOR INITIAL INFORMATION | |

RECORD OF REVISIONS

| | | |
|-----------------------|------------|----------|
| MATERIAL | WT AIR | WT WATER |
| | - kg (E) - | - kg (E) |
| FINISH | DRAWN | CMI |
| | DATE | 12/05/04 |
| USO, TOLERANCES TO BE | CHECK | EBR |
| | APPRV. | CMI |
| | ENGR. | CMI |

sub-Atlantic

Woodburn Road,
Blackburn Business Park, Blackburn,
Aberdeen. U.K. AB21 0PS
Tel: ++44 (0) 1224 798660
Fax: ++44 (0) 1224 798661

SCALE (UOS) **1:3**

ORIG. SIZE **A3**

| | |
|--------------|---|
| PROJECT | COMPENSATORS |
| TITLE | COMPENSATOR - 13.5 LITRE (VARIOUS CONFIGURATIONS) GENERAL ARRANGEMENT DRAWING |
| Sheet 1 of 1 | |
| DOC. No. | 2442-GA |
| REV | 5 |