

Submersible Motors & HPU's



Our high efficiency submersible motors and HPU's are the most reliable available in the marketplace. Available in sizes varying from 15 to 280 kW / 20 to 375 HP, they are the perfect power source supply for ROVs Trenchers, TMS and Tooling applications.

- High Reliability
- Outputs Shaft each End of Motor
- Shaft Powers from 15 to 280 kW (20 to 375 HP)
- Industry Proven Windings
- 1800 rpm Synchronous Speed
- Water Ingress and Temp. Sensors
- Various Voltage Options (3000 Volts Standard)
- Interface Kits for a Range of Hydraulic Pumps
- Motor Options for Pump Drives with 3600 rpm Shaft Speed
- Efficient Design Requires No External Cooler

Our motors and HPU's are ideal for driving thruster systems, excavation and hydraulic tools requiring high power inputs. The submersible motor can also be used to drive other types of rotating machinery such as water pumps for trenching machines. The distinctive feature of our submersible motors is the finned end cap design that provides high efficiency cooling due to the heat transfer surface area. This eliminates the need for forced external cooling on the larger motors. Motor winding temperature and water ingress sensors are included for connection to customers control system.

Interfacing Pump to Motor

This comprehensive range of submersible motors is available in shaft power outputs from 15 to 280 kW (20 to 375 HP) across four motor frame sizes. All motors incorporate interfaces at each end of the allowing two output drives to be run from a single motor. Dedicated pump interface kits allow the accurate matching of hydraulic pump model, type and displacement to obtain desired hydraulic characteristics.

kW Shaft	HP Shaft	Frame Size
15	20	160
56	75	180
91	125	180
110	150	225
150	200	225
280	385	280

Pump Interface

Hydraulic pumps can be attached to each end of the motor by means of a dedicated 'plug-in' Interface Kit that includes a bell housing and flexible drive element.

The flexible element reduces shock loading and prevents problems associated with misalignment. Interface kits are available for most commonly used pumps and new designs can be supplied for customer specified or supplied pumps.

If only one pump is required, the opposite end is fitted with a blacking kit. Pumps can be easily fitted and replaced in the field with the correct interface kit.



Pump Options

Typical pumps used in ROV applications include, Rexroth A10 / A4 ranges and Linde HPR range. Other pumps can be interfaced as required with a dedicated Interface Kit. Compensated pumps are generally fitted that automatically unload when there is no power demand.

Voltage and Speed

Standard voltage is 3000 VAC but can be supplied as options such as 2400 or 1100 VAC.

Standard speed is 1800 rpm synchronous @ 60 Hz, 4 pole but can be supplied as 3600 rpm synchronous @ 60 Hz, 2 pole as an option (4 pole is preferred due to enhanced pump reliability).

Testing

All motors and HPU's are fully run-in at full load prior to shipment. A test certificate is supplied with each unit stating all the recorded outputs such as power input and output, temperature, pressure, flow, etc.

Compensation Oil

The motor must be filled with a compensation oil and positively compensated to approx 0.5 bar / 7 psi overpressure. Transformer or hydraulic oil can be used although hydraulic tends to be preferred choice with ROV operators. Sprung compensators are available from Sub Atlantic.



Main Power Connection

Units can be supplied with a Burton 3000 Volt bulkhead connector for



powers outputs up to 91 kW / 125 HP and water blocked, cable tails in an oil filled Tygon tube for direct connection to the ROV power supply junction box.

Water Sensor

As standard configuration, a contact type water ingress sensor is included in the lowest part of the housing. Customer specified sensors can also be fitted on request.

Temperature Sensors

As standard configuration, three PT-100 type sensors are included in each of the phase windings for monitoring their respective temperatures. Additionally, customer specified sensors can also be fitted on request (to monitor oil temperature).

Sensor Electrical Connector

As standard configuration, a Burton 1508 shell bulkhead connector is used for the transmission of the sensor data

Simple Cool Running Design

All Sub-Atlantic motors incorporate a unique high cooling capacity end cap design to ensure that the motor runs cool in all water conditions



Basic HPU Configurations

**General selection of motors with different pump options shown for example
(weights are for motor only as pumps vary depending on model)**

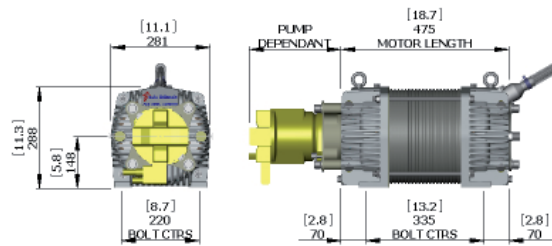

15 kW / 20 HP Motor
(160 frame size)
Wt in Air: 115 kg / 253 lb
Wt in Sea Water: 85 kg / 187 lb
(shown with main pump and blanking cap)

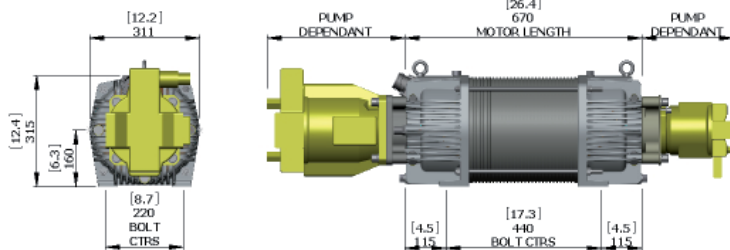

56 kW / 75 HP Motor
(180 frame size)
Wt in Air: 215 kg / 474 lb
Wt in Sea Water: 172 kg / 379 lb
(shown with main and auxiliary pumps)

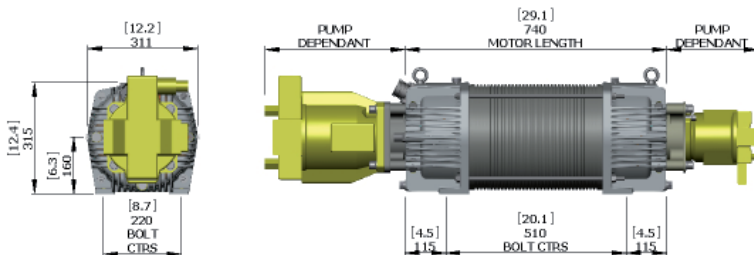

93 kW / 125 HP Motor
(180 frame size)
Wt in Air: 293 kg / 645 lb
Wt in Sea Water: 190 kg / 418 lb
(shown with main and auxiliary pumps)

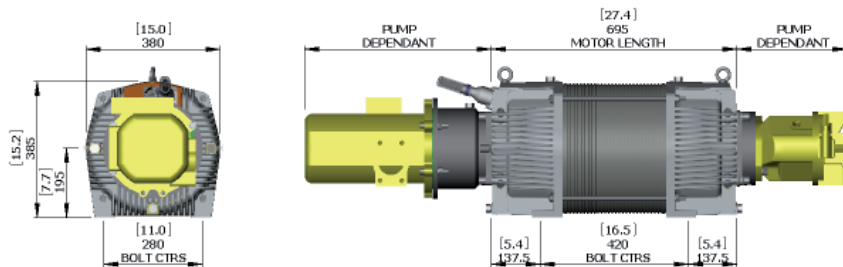

110 kW / 150 HP Motor
(225 frame size)
Wt in Air: 322 kg / 710 lb
Wt in Sea Water: 248 kg / 547 lb
(shown with main and auxiliary pumps)

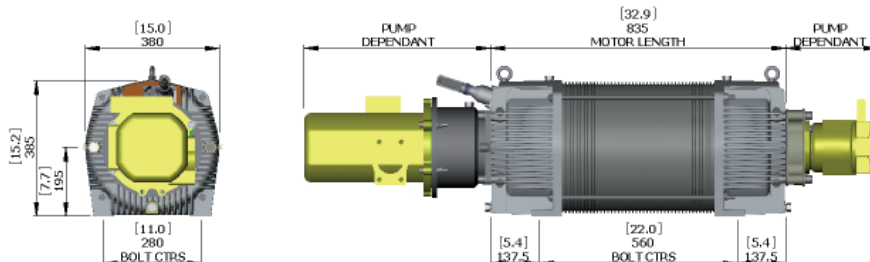

150 kW / 200 HP Motor
(225 frame size)
Wt in Air: 412 kg / 908 lb
Wt in Sea Water: 321 kg / 707 lb
(shown with main and auxiliary pumps)

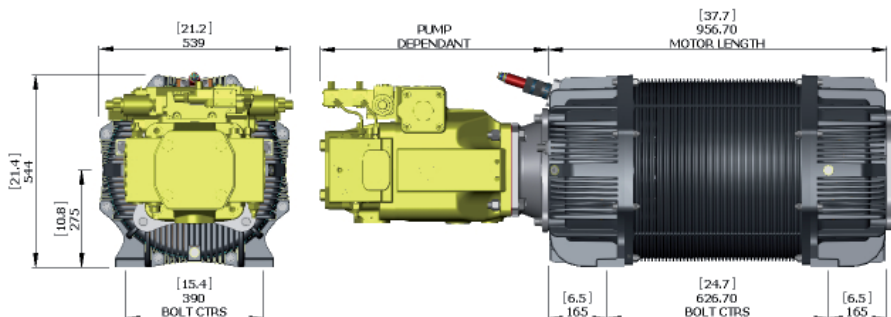

280 kW / 375 HP Motor
(280 frame size)
Wt in Air: 790 kg / 1741 lb
Wt in Sea Water: 596 kg / 1313 lb
(shown with main pump and blanking cap)

The specification details are illustrative for marketing purposes only. Actual equipment may be different as a result of product improvement or other reasons. Specific interface and performance information should be reconfirmed at time of order placement.



Sub-Atlantic Ltd. Woodburn Road, Blackburn Business Park, Blackburn, Aberdeen. AB21 0PS. UK
T: +44 1224 798660 F: +44 1224 798661 E: sales@sub-atlantic.co.uk

Sub-Atlantic Inc. 10642 West Little York, Suite 100, Houston, TX 77041-4014-USA
T: +1 713 329 8730 F: +1 713 329 8299 E: sales@sub-atlantic.com